

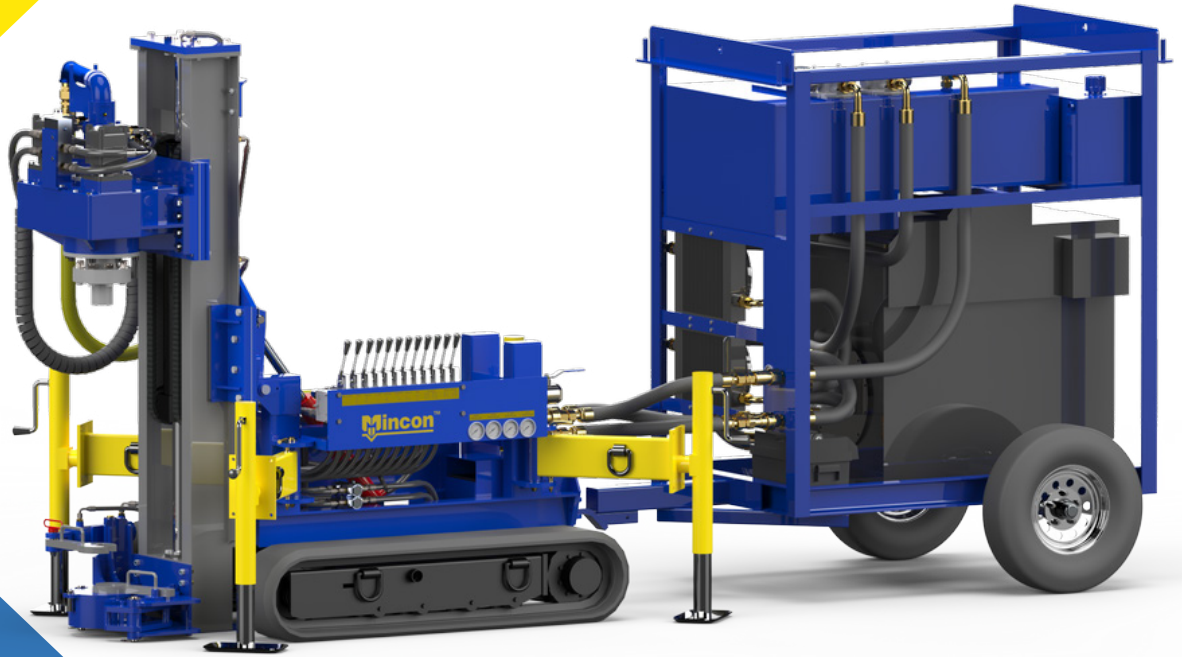

The Driller's Choice



ROCK DRILL R405

LOW HEADROOM - HIGH POWER - MICROPILING - GEOTHERMAL APPLICATIONS



mincon.com

R405



ROCK DRILL R405

The Rock Drill R405 is a low headroom micro piling drilling unit ideally suited for restricted access drilling sites and underground geothermal applications. Compatible with mud or air drilling setups. Standard features include breakout clamps, separate power unit, width adjustable crawler tracks, adjustable jack legs and a high torque drill head.

AVAILABLE OPTIONS

- Double Breakout Clamps.
- Safety Clamp System. Hands-free breakout.
- Auxiliary Winch. 42' rope / 1,470 lbs pull.
- Winch Extension Package. 2,000 lbs (907 kg) pull.
- Remote Controls. Tracks Only or Tracks, Rotation & Feed.*
- Dust Suppression System for DTH Hammer Drilling.
- Trip Wire Safety System. (European Spec).
- Mast Mounted Flood Lights.
- Mono Mud Pump. 150-180 gpm / 300-800 psi.*
- Longer Crawler Tracks.*

Key Features

Gate Clamps & Breakout Wrench with 8.8" ID (223 mm).

3-Position Manual Stabilizer Jack Legs.

Auxiliary Spool Control Function. (optional)

Separate Power Unit - Skid Mounted. (optional)

Width Adjustable Crawler Tracks. 34" - 52".

Rock Drill R405



UP TO
10,000
FT.LBS OF
TORQUE

SPECIFICATIONS

Power & Hydraulics

	IMPERIAL	METRIC
SYSTEM PRESSURE	3,000 psi	206 bar
MAX FLOW	33 gpm	125 lpm
MAX PULLBACK	22,000 lbs	10,000 kg
MAX PUSHDOWN	16,000 lbs	7,257 kg
ENGINE POWER	83 hp	61 kW
FUEL TANK	31 gal	117 ltr
HYDRAULIC TANK	55 gal	189 ltr
COOLING SYSTEM	Air cooled	

Rotary Heads JT-200 Series

	IMPERIAL	METRIC
MAX TORQUE	10,400 ft - lbs with JT205	14,000 Nm
MAX SPEED	205 RPM with JT222-M	
THROUGH BORE	2 - 3/8"	60mm
SPEEDS	2-speed variable	

Mast Movement

SIDE TO SIDE	+ / - 30°
FORE AND AFT	+ 3° to - 90°
SLIDE	Available Option

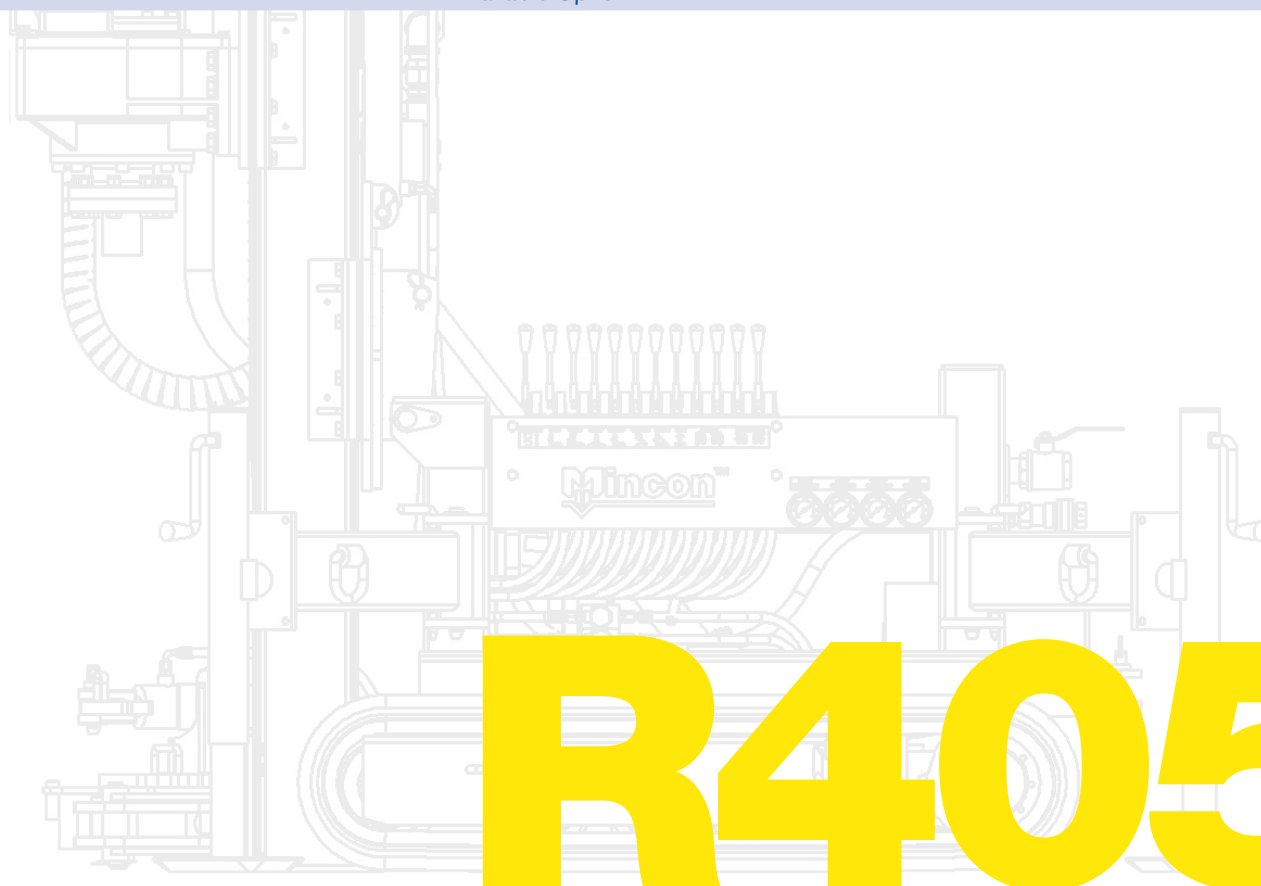

TECHNICAL DRAWING

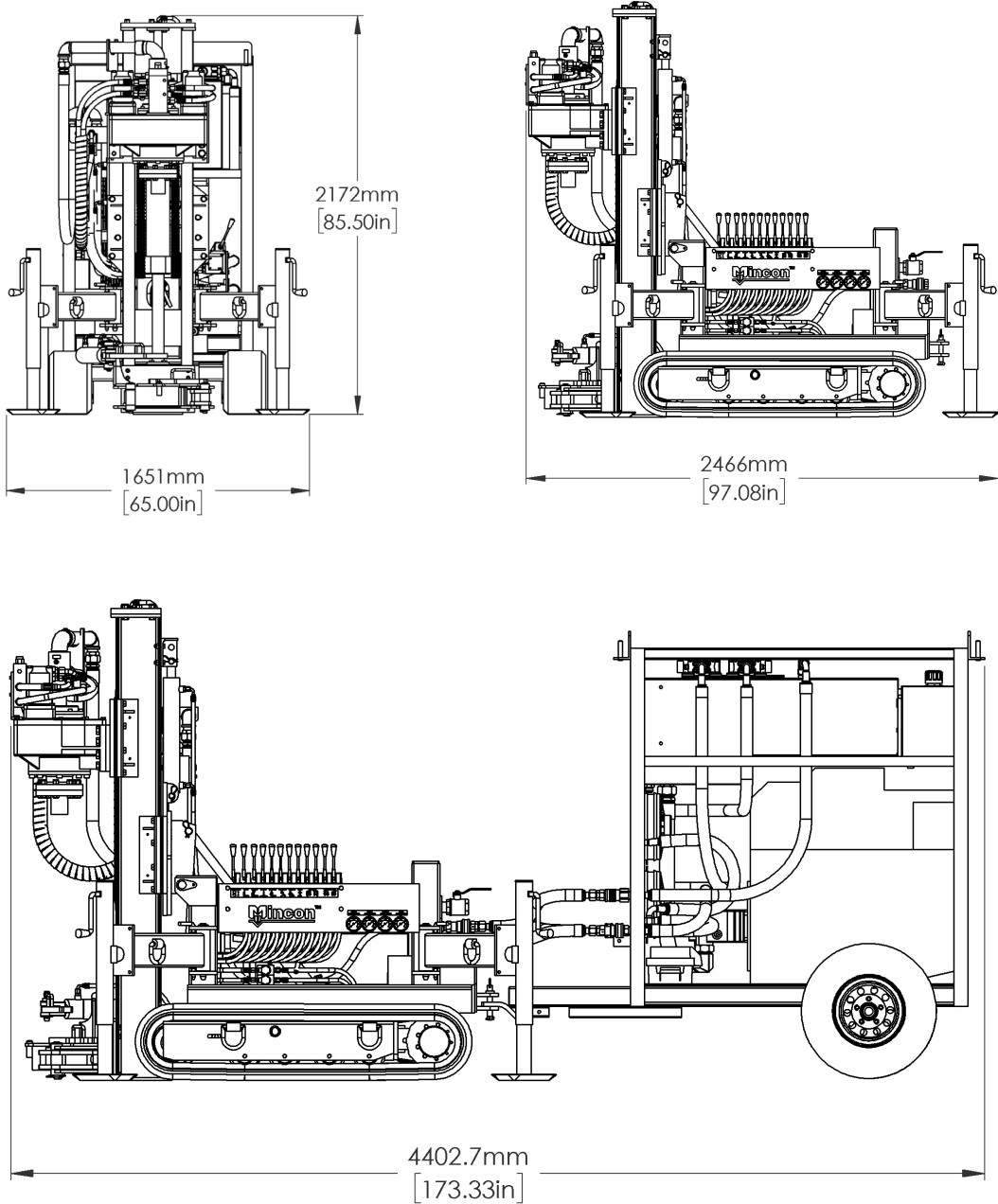

Dimensions & Weight

	IMPERIAL	METRIC
HEIGHT (DRILLING POSITION)	7' 3"	2,172 mm
HEIGHT (TRANSPORT POSITION)	59"	1,499 mm
LENGTH (DRILLING POSITION)	83"	2,108 mm
MAST STROKE	4' 7"	1,397 mm
WIDTH	34"	862 mm
WEIGHT (RIG ONLY)*	3,300 lbs	1,500 kg
TRACK ADJUSTABLE WIDTH	34" - 52"	863 - 1,320 mm
TRACK LENGTH	40"	1,016 mm

* Dependant on options / Additional upgrades may be required

A large yellow Mincon drilling rig is shown in a collage of images. The rig is mounted on a tracked chassis and features a prominent vertical mast with a drilling head. The mast has "SCHWABER" written on it. The rig is set against a background of green trees and a cloudy sky. The text "The Driller's Choice" is overlaid in white on a blue background that forms a large, stylized letter 'M' shape behind the rig images.

The Driller's Choice

MINCON INC
603 Centre Ave NW, Roanoke,
VA 24016, USA
T. +1 540-344-9939
E. salesusa@mincon.com
W. mincon.com

AMERICAS REGION · EUROPE AND MIDDLE EAST REGION · AFRICA REGION · ASIA PACIFIC REGION